

| DESCRIPTION | |
|-----------------------|----------------|
| CODE | FINISH |
| SUREFLOW 80 PL | PLASTIC |

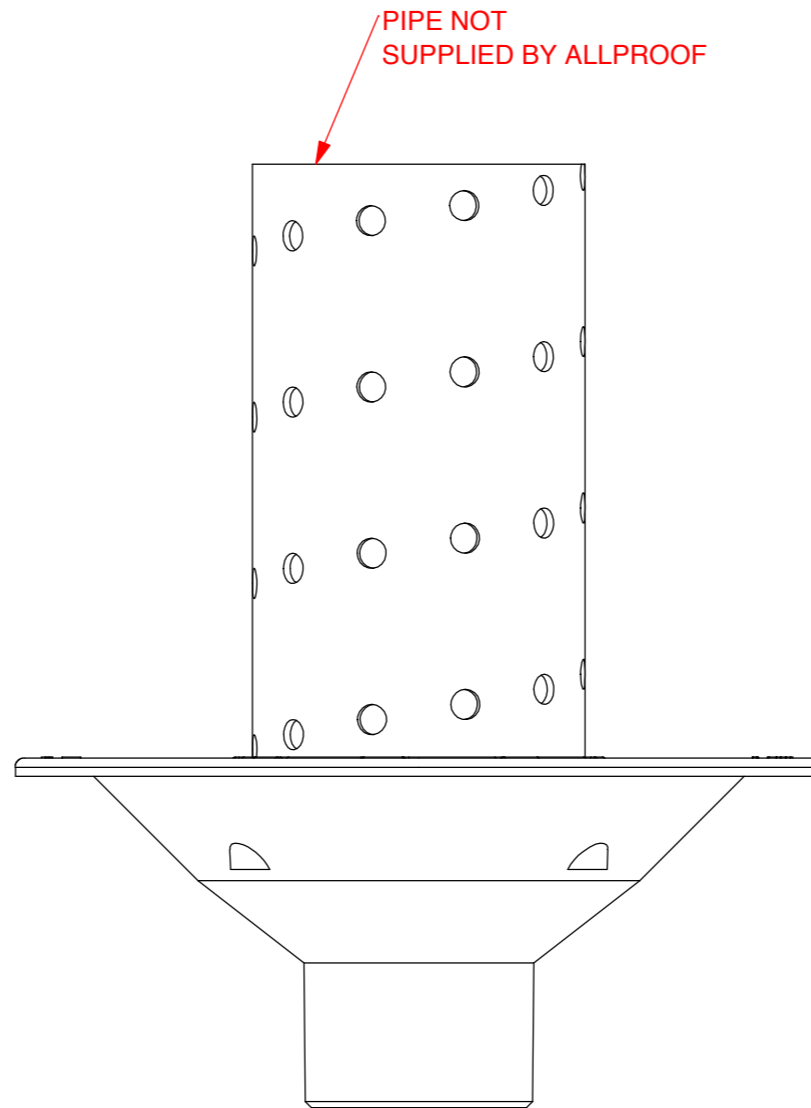

100MM CLAMP RING

SUREFLOW 80MM BASE

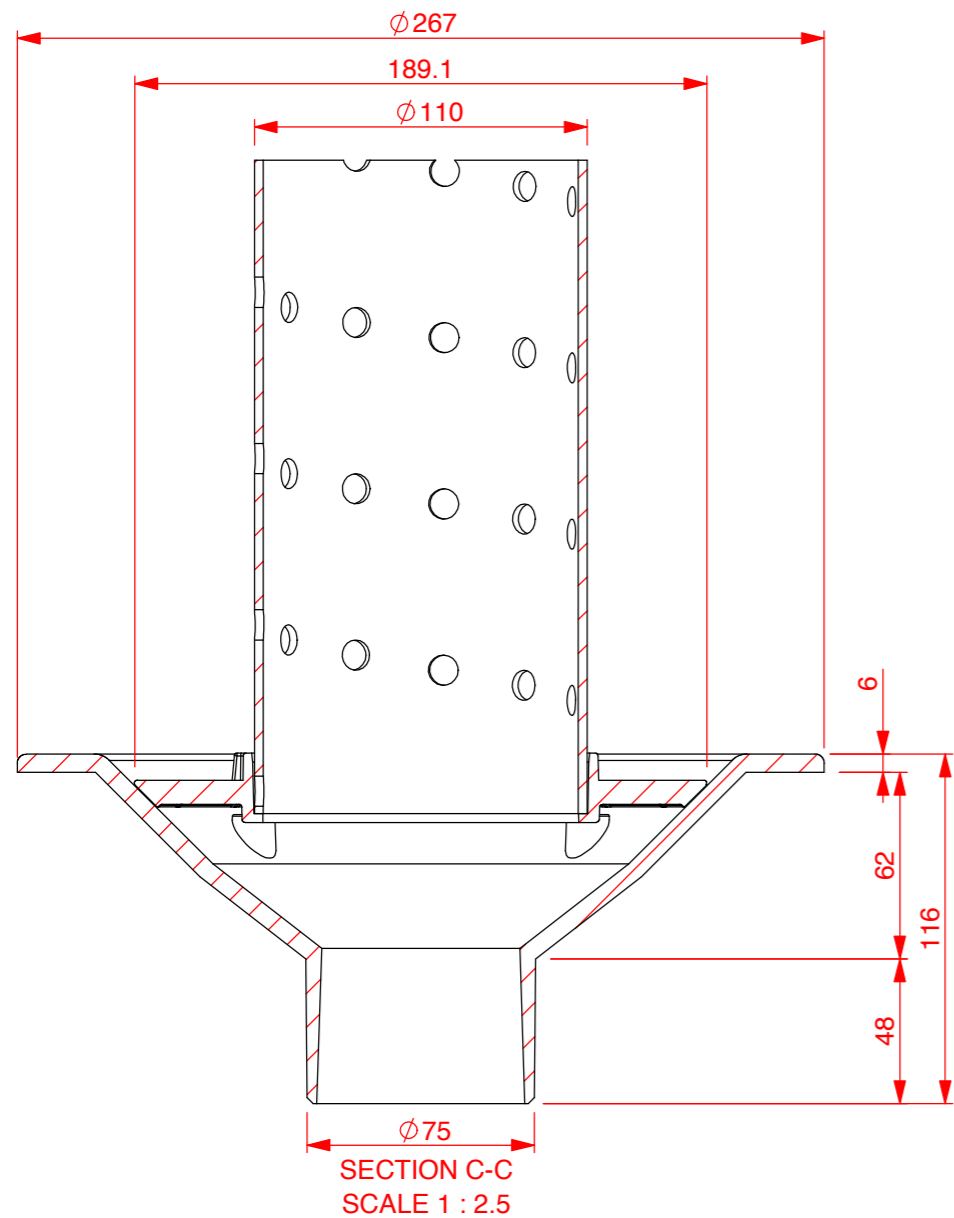
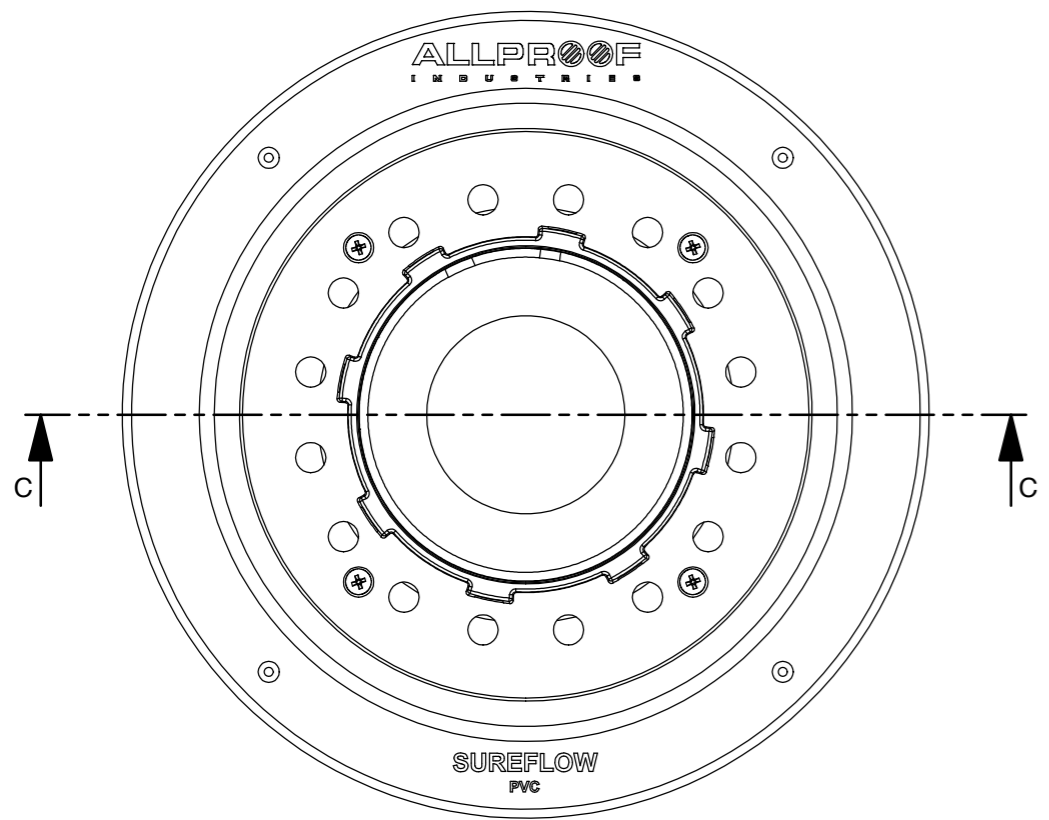
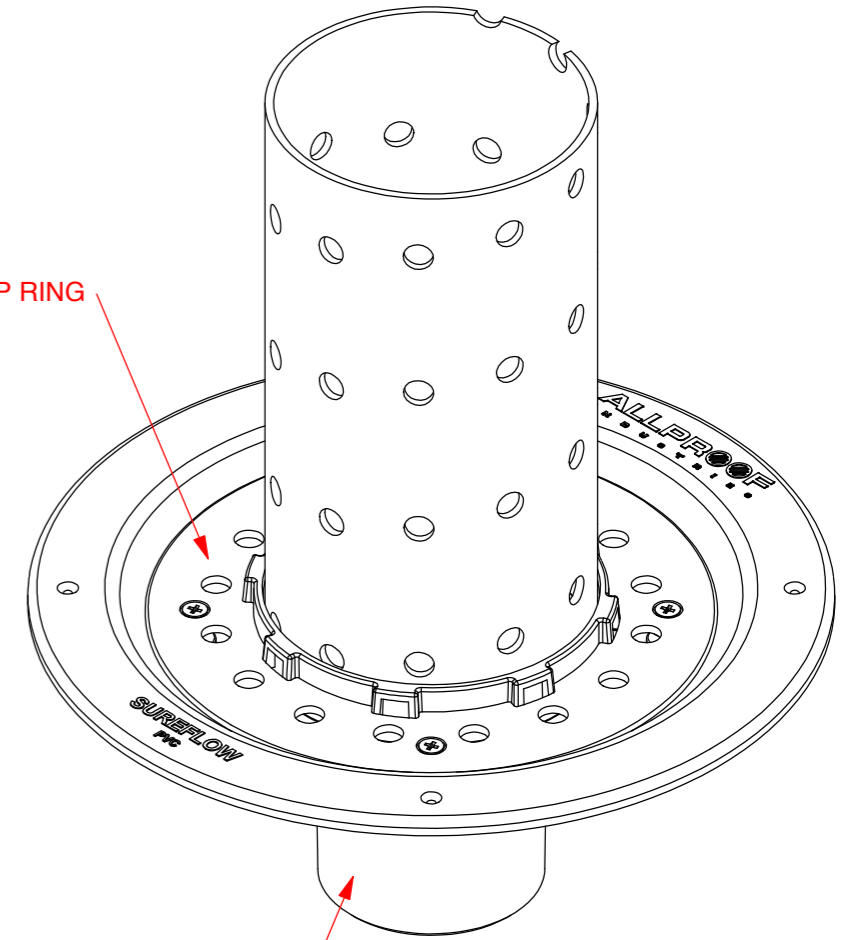

| REVISION | CHANGE | DESCRIPTION | SL | DATE |
|--|--------|--------------------|-----------------------------------|--------------|
| XXX | XXX | XXX | SL | XXX |
| DO NOT SCALE DRAWING | | TITLE | | |
| REQUESTED | XXX | DATE | 80MM SUREFLOW PLANTERBOX ASSEMBLY | |
| DRAWN | S.L. | DATE | | |
| APPROVED | | DATE | APPLICABLE STANDARD(S): | |
| MATERIAL | | DRAWING REF NUMBER | | |
| XXX | | SUREFLOW PL80 | | |
| TOOL NUMBER | | SCALE (UOS) | | SHEET 1 OF 1 |
| PART WEIGHT(GRAMS) | | 1 : 2.5 | | |
| FILE | | UNITS = MM | | |
| S:\CAD FILES\2018\DIVERSE\CP\SUREFLOW80 PL | | | | |

DISCLAIMER : THE DESIGN SUGGESTION IS PROVIDED FOR EVALUATION PURPOSES ONLY.
IT IS NOT TO BE CONSIDERED A FULL DESIGN AS WE ARE NOT THE CONSULTING ENGINEERS. WE ARE MANUFACTURERS. WE ARE NOT PRIVY TO ALL THE INFORMATION PERTAINING TO THIS MATTER AND WE HAVE NO CONTROL OVER THE PROJECT INSTALLATION OF THE PRODUCT. THE DESIGN SUGGESTION IS PROVIDED WITHOUT OBLIGATION. DESIGN IS TO BE CONFIRMED AND APPROVED BY THE ARCHITECT, HYDRAULICS ENGINEER, OR PROJECT MANAGER. ACCURATE MEASUREMENTS SHOULD BE CONFIRMED BY THE PERSON APPROVING THE DESIGN. ALLPROOF ACCEPTS NO LIABILITY FOR THE IMPROPER USE OF THE DESIGN SUGGESTION.

| DESCRIPTION | |
|----------------|---------------|
| CODE | FINISH |
| SUREFLOW100 PL | BLACK PLASTIC |

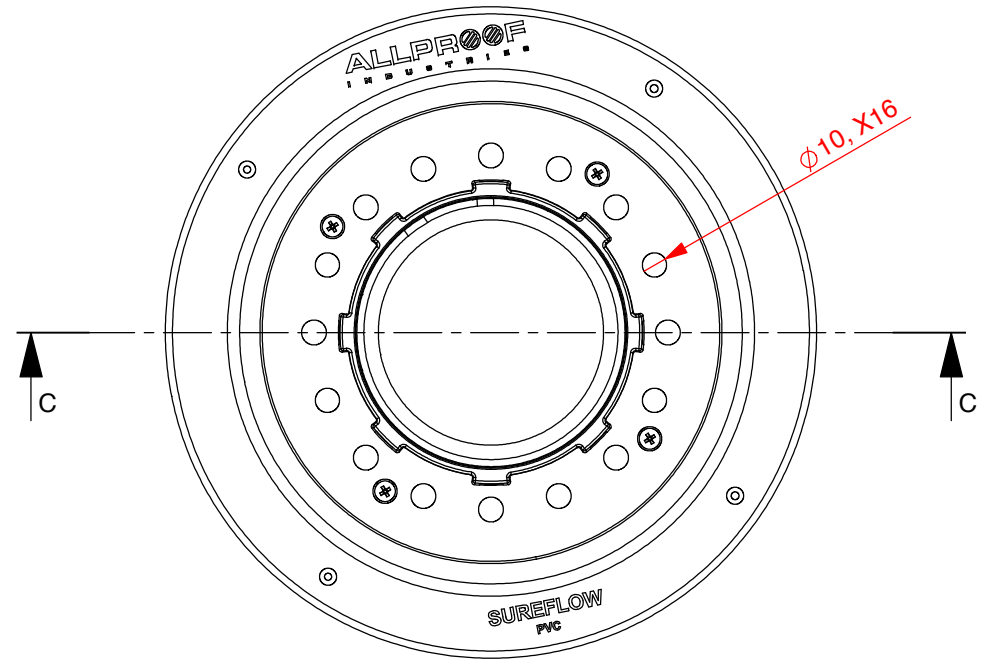

TOP

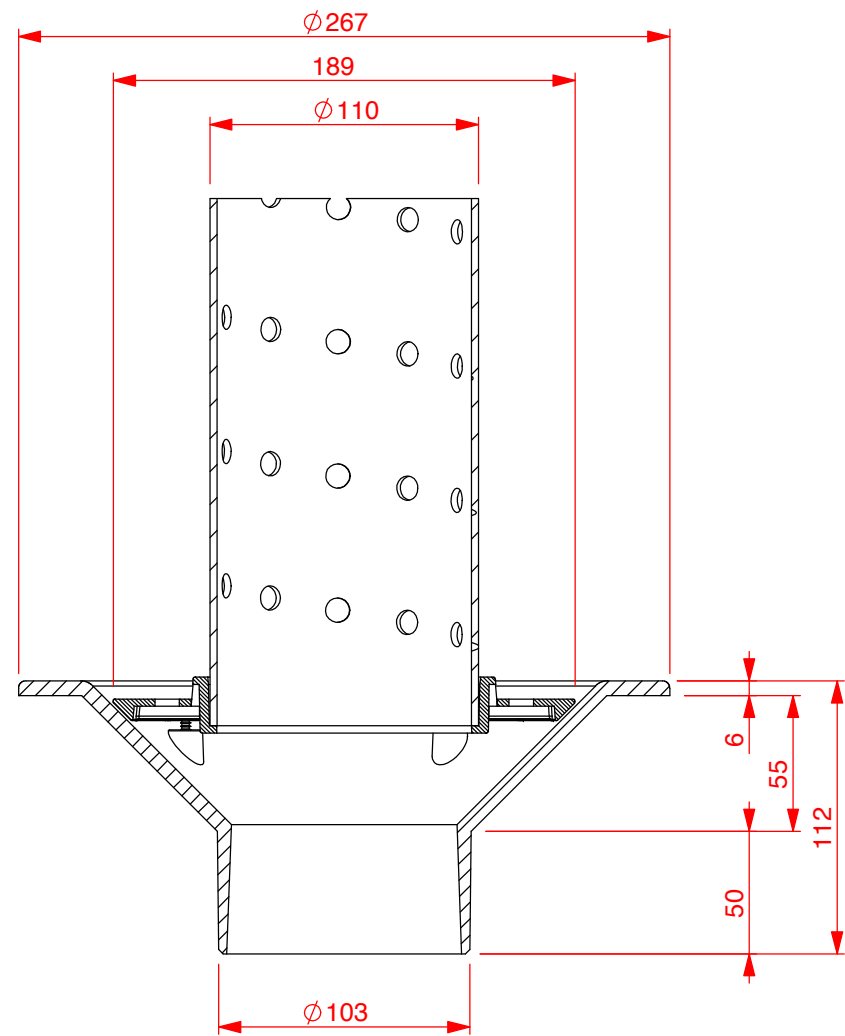

SECTION C-C

PIPE NOT SUPPLIED BY ALLPROOF

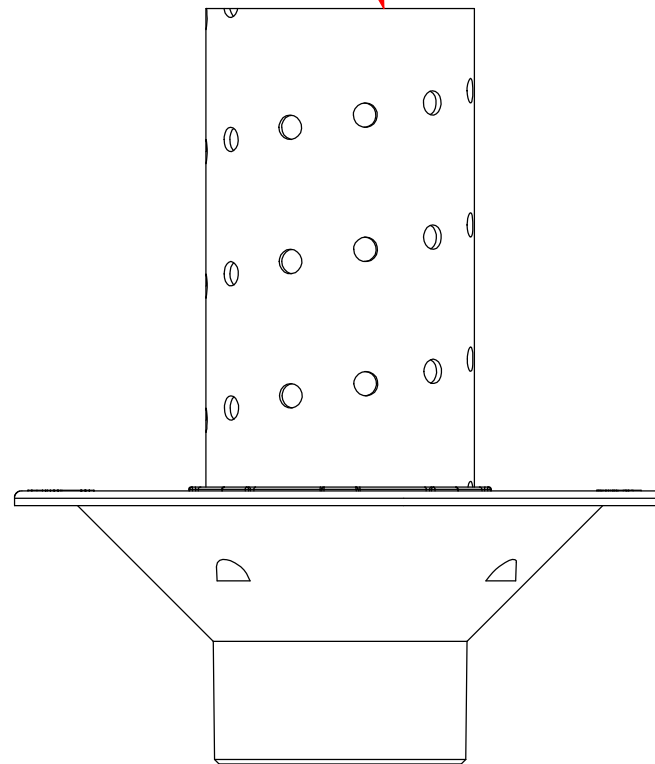

RIGHT

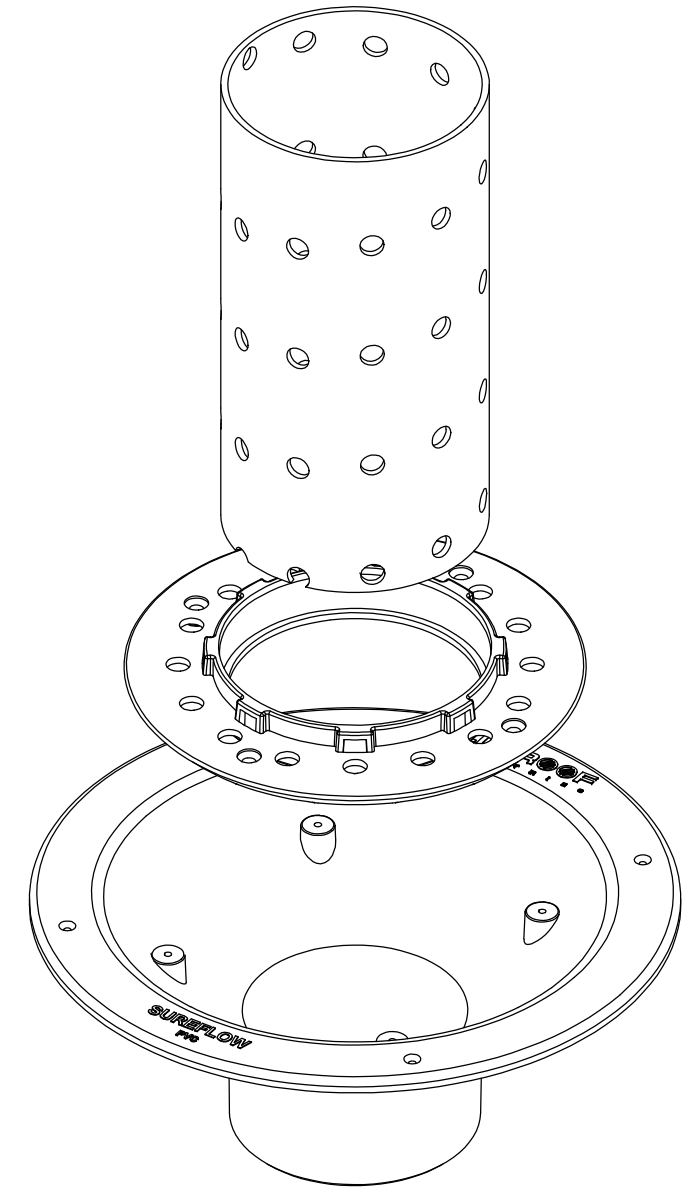

| REVISION | CHANGE | DESCRIPTION | DRAWN | DATE |
|----------------------|------------|-------------------------|----------------|------|
| DO NOT SCALE DRAWING | | TITLE | | |
| REQUESTED | AJ | DATE | 2.6.2015 | |
| DRAWN | S.L. | DATE | 2.6.2015 | |
| APPROVED | | DATE | | |
| MATERIAL | | APPLICABLE STANDARD(S): | | |
| ABS, PVC | | DRAWING REF NUMBER | SUREFLOW100 PL | |
| A3 | UNITS = MM | SCALE | 1 : 2 (UOS) | |
| | | | SHEET 1 OF 18 | |

DISCLAIMER - THE DESIGN SUGGESTION IS PROVIDED FOR EVALUATION PURPOSES ONLY.
IT IS NOT TO BE CONSIDERED A FULL DESIGN AS WE ARE NOT THE CONSULTING ENGINEERS, WE ARE MANUFACTURERS. WE ARE NOT PRIVY TO ALL THE INFORMATION PERTAINING TO THIS MATTER AND WE HAVE NO CONTROL OVER THE PROJECT INSTALLATION OF THE PRODUCT. THE DESIGN SUGGESTION IS PROVIDED WITHOUT OBLIGATION. DESIGN IS TO BE CONFIRMED AND APPROVED BY THE ARCHITECT, HYDRAULICS ENGINEER, OR PROJECT MANAGER. ACCURATE MEASUREMENTS SHOULD BE CONFIRMED BY THE PERSON APPROVING THE DESIGN. ALLPROOF ACCEPTS NO LIABILITY FOR THE IMPROPER USE OF THE DESIGN SUGGESTION.

| | |
|--------------------|---|
| TOOL NUMBER | 0.0 |
| PART WEIGHT(GRAMS) | 0.0 |
| FILE | S\CAD FILES\2014\DRAINAGE\NJ\SF RISER 100_PLANTER BOX |

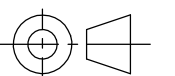

Description

| Code | Finish |
|------------------|------------|
| Sureflow100.88PL | ABS, Black |

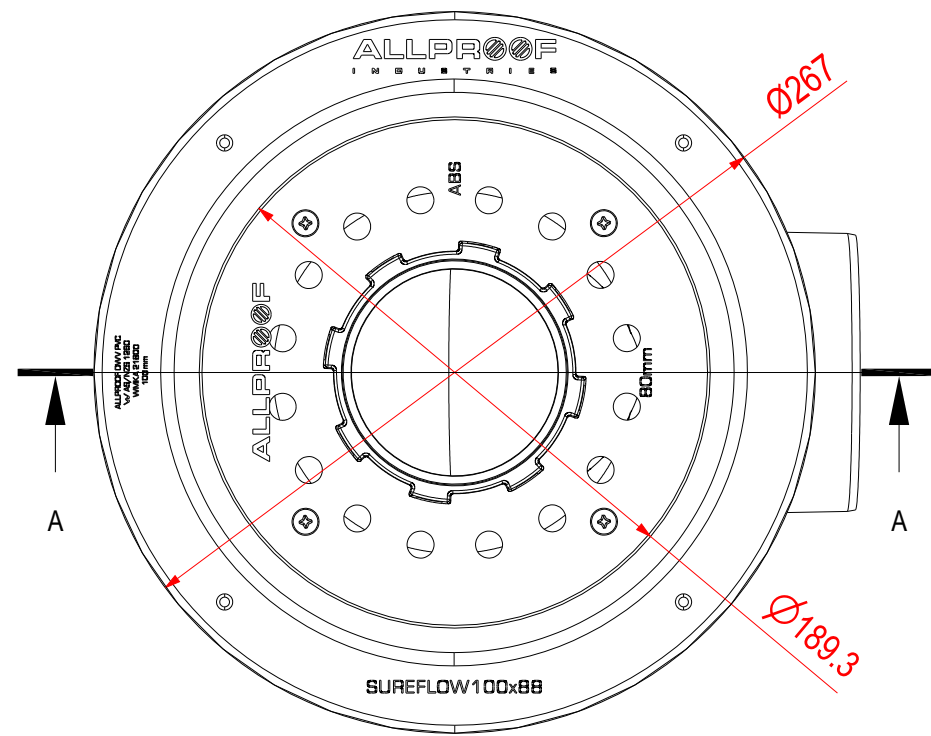

Pipe not supplied by Allproof

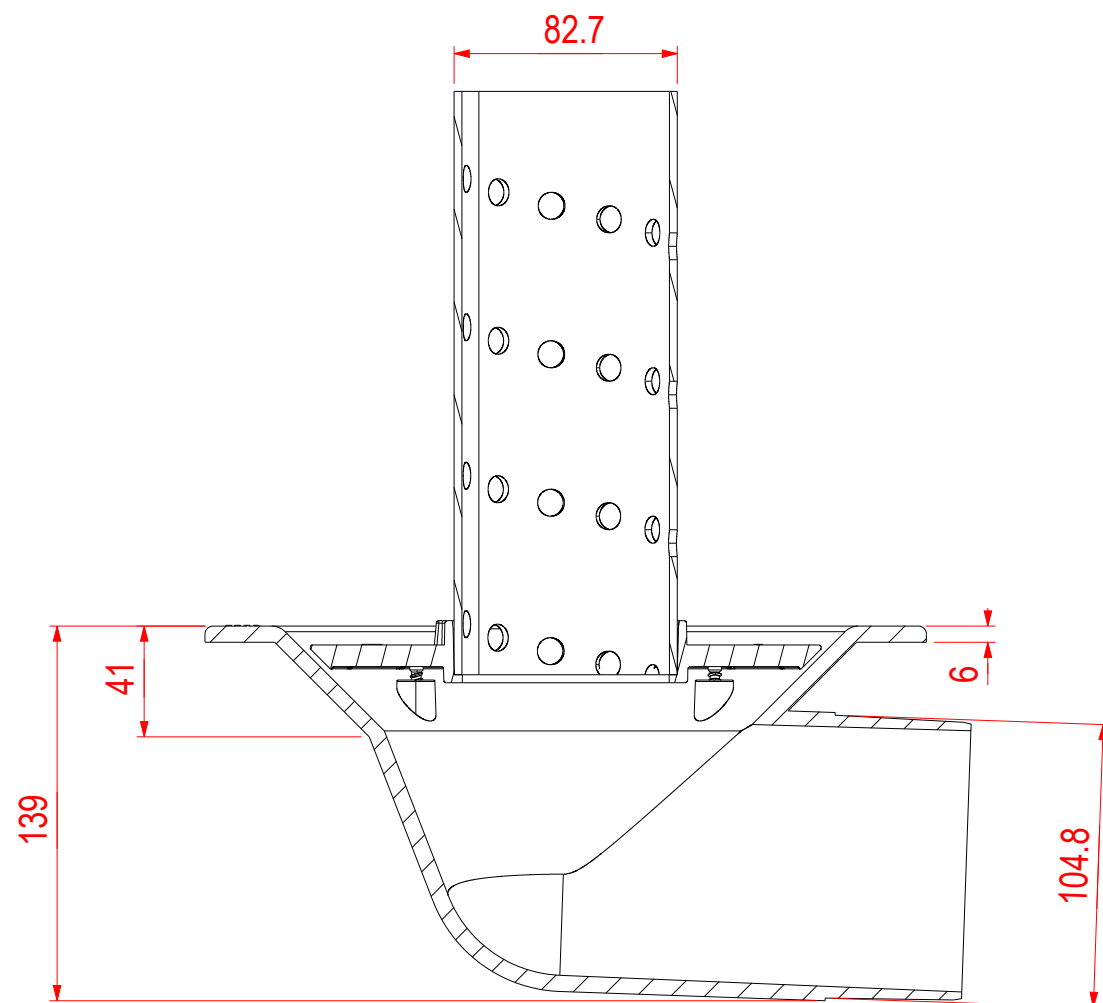
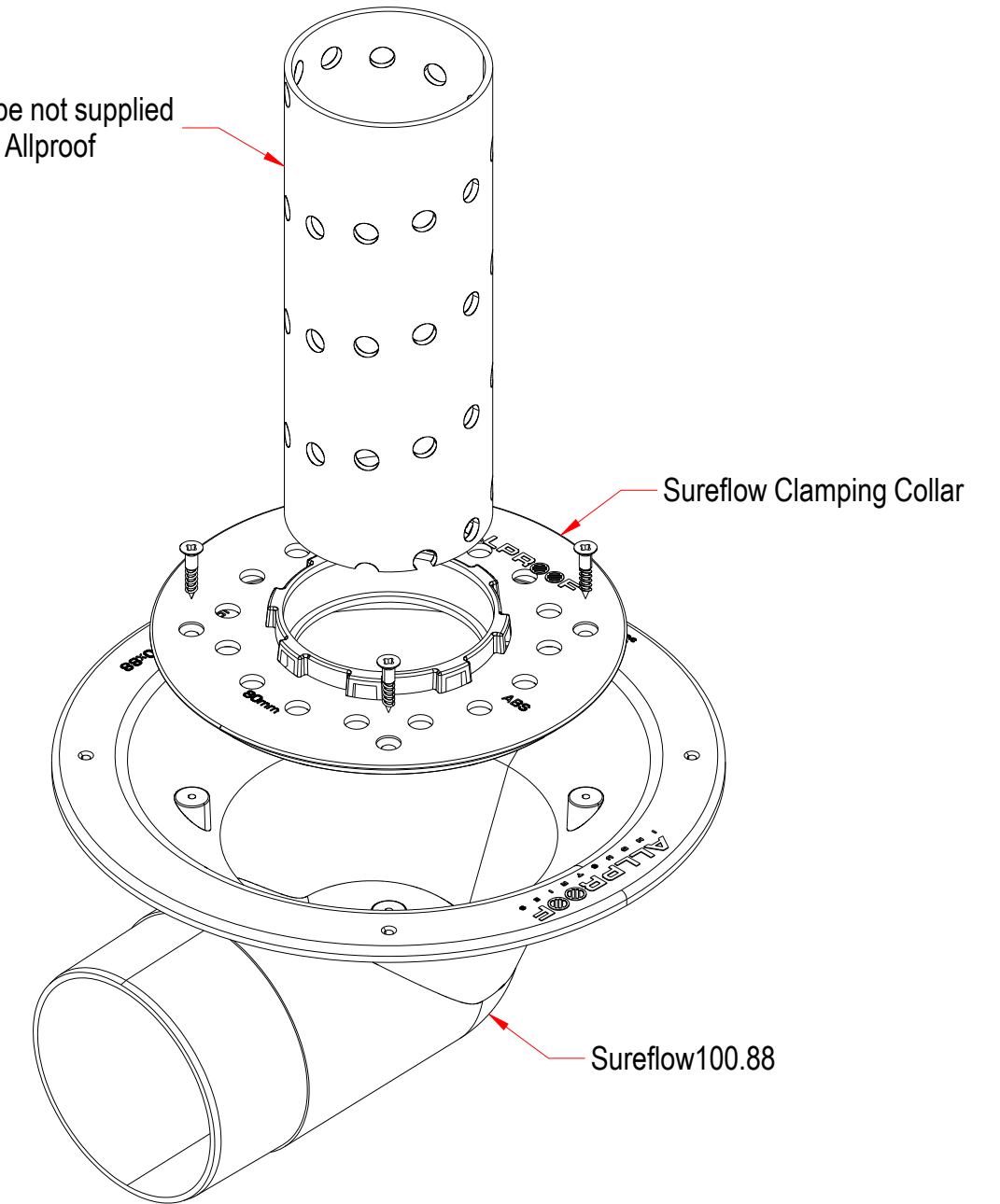

Section A-A

This product drawing is provided for informational purposes only. The drawing is based upon information supplied to Allproof and may not contain the full details required for the contract. We strongly recommend that you obtain appropriate expert advice from engineers, architects and other expert personnel to ensure the accuracy and completeness of the drawing and compliance with local authorities and legislation. Allproof Industries NZ Limited accepts no liability whatsoever for any loss or damage of any kind arising from provision of this drawing to you, including consequential loss whether suffered or incurred by you or another person or entity and whether in contract, tort or otherwise. You indemnify Allproof Industries NZ Limited against any liability that we incur in respect to loss or damage of any kind, including damage to property, death or personal injury, suffered or incurred by any person or entity and whether in contract, tort or otherwise, which arises from provision of this drawing to you, and any reasonable costs, claims, demands and expenses arising out of or in connection with that liability.

| | | | |
|--------------------------|----------------------|---------------------|----------------|
| Job Number: TBC | DO NOT SCALE DRAWING | | |
| Drawn by: Cole | Date: 29/04/22 | Requested by: Chris | Date: 29/04/22 |
| Title: Sureflow100.88 PL | | | |
| Material: PVC & ABS | Page 1 of 1 | Rev 1 | |

| DESCRIPTION | |
|----------------|---------------|
| CODE | FINISH |
| SUREFLOW150 PL | BLACK PLASTIC |

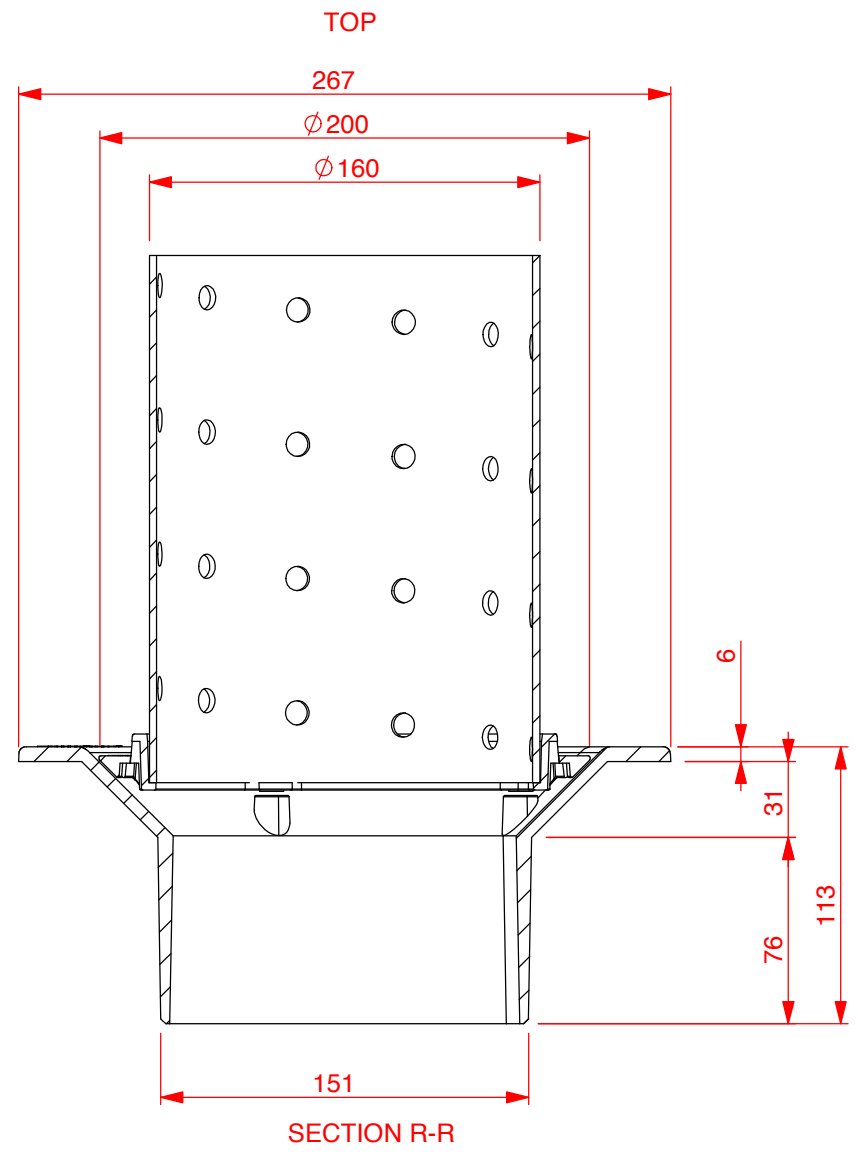
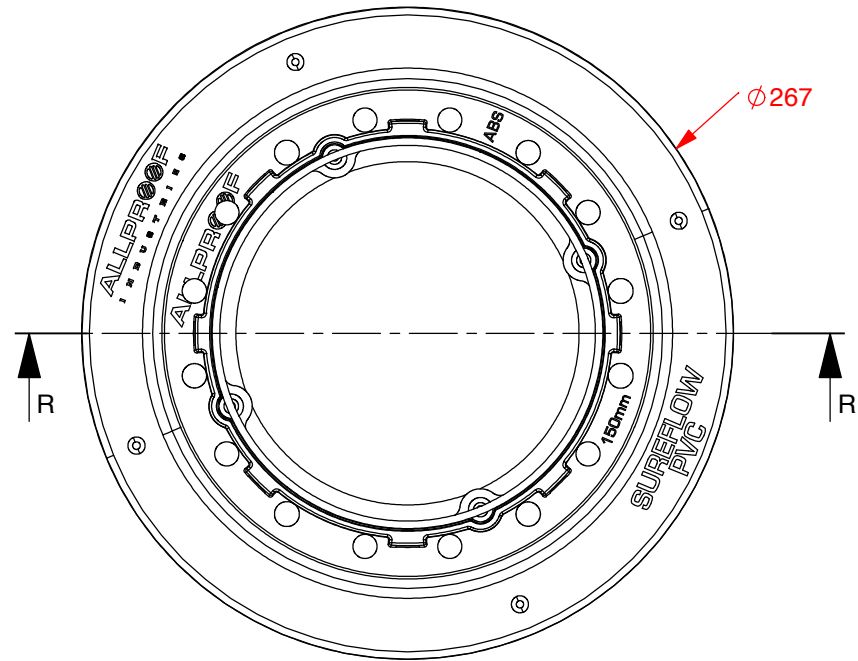

PIPE NOT SUPPLIED BY ALLPROOF

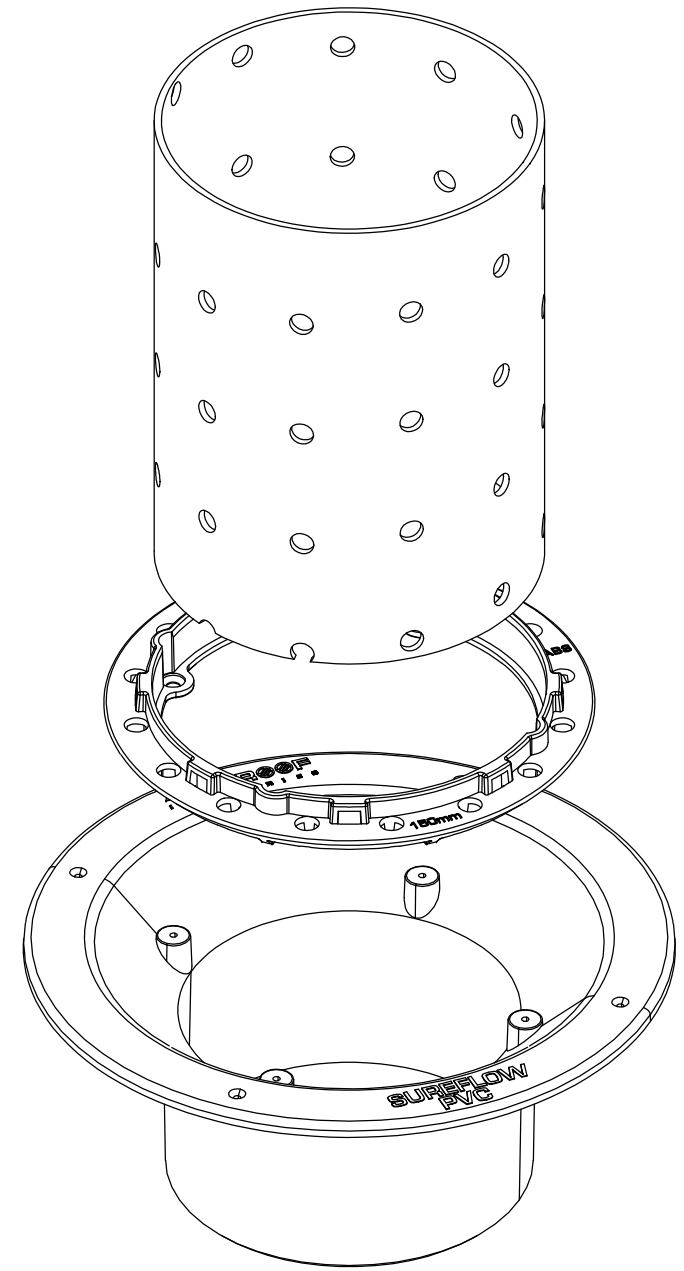
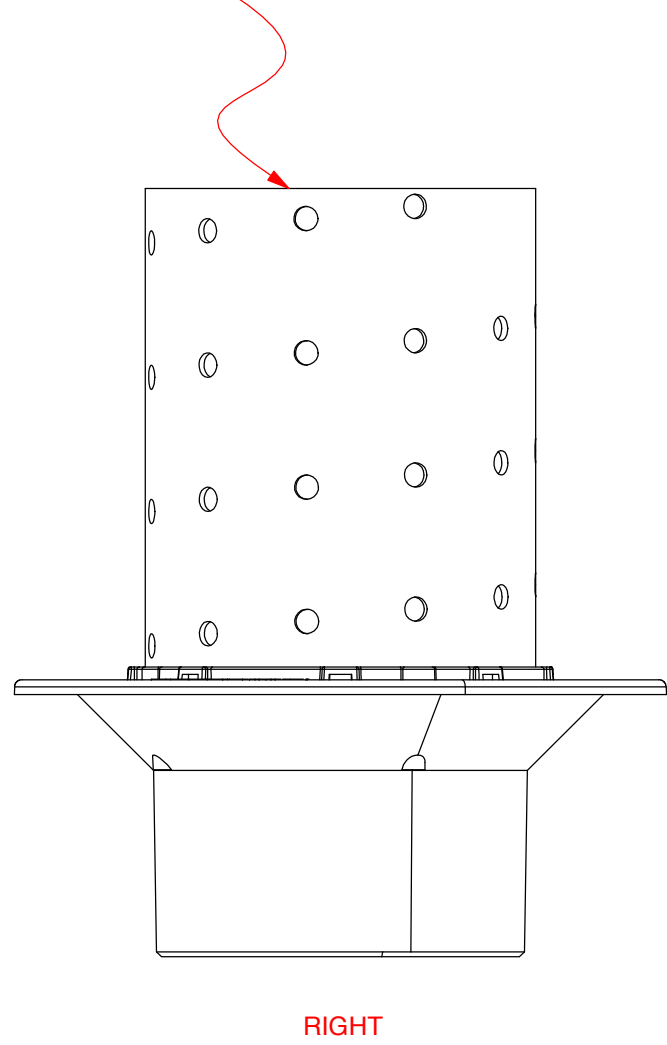

| REVISION | CHANGE | DESCRIPTION | DRAWN | DATE |
|----------------------|------------|-------------------------|----------------|------|
| DO NOT SCALE DRAWING | | TITLE | | |
| REQUESTED | AJ | DATE | 2.6.2015 | |
| DRAWN | S.L. | DATE | 2.6.2015 | |
| APPROVED | | DATE | | |
| MATERIAL | | APPLICABLE STANDARD(S): | | |
| ABS, PVC | | DRAWING REF NUMBER | SUREFLOW150PL | |
| A3 | UNITS = MM | SCALE | 1 : 2 (UOS) | |
| | | | SHEET 13 OF 18 | |

DISCLAIMER - THE DESIGN SUGGESTION IS PROVIDED FOR EVALUATION PURPOSES ONLY.
IT IS NOT TO BE CONSIDERED A FULL DESIGN AS WE ARE NOT THE CONSULTING ENGINEERS, WE ARE MANUFACTURERS. WE ARE NOT PRIVY TO ALL THE INFORMATION PERTAINING TO THIS MATTER AND WE HAVE NO CONTROL OVER THE PROJECT INSTALLATION OF THE PRODUCT. THE DESIGN SUGGESTION IS PROVIDED WITHOUT OBLIGATION. DESIGN IS TO BE CONFIRMED AND APPROVED BY THE ARCHITECT, HYDRAULICS ENGINEER, OR PROJECT MANAGER. ACCURATE MEASUREMENTS SHOULD BE CONFIRMED BY THE PERSON APPROVING THE DESIGN. ALLPROOF ACCEPTS NO LIABILITY FOR THE IMPROPER USE OF THE DESIGN SUGGESTION.

| | |
|--------------------|---|
| TOOL NUMBER | 0.0 |
| PART WEIGHT(GRAMS) | 0.0 |
| FILE | S\CAD FILES\2014\DRAINAGE\NJ\SF RISER 100_PLANTER BOX |